

Replacement Guide of Comparable "Manchester" Adapters for "Modern" Machines

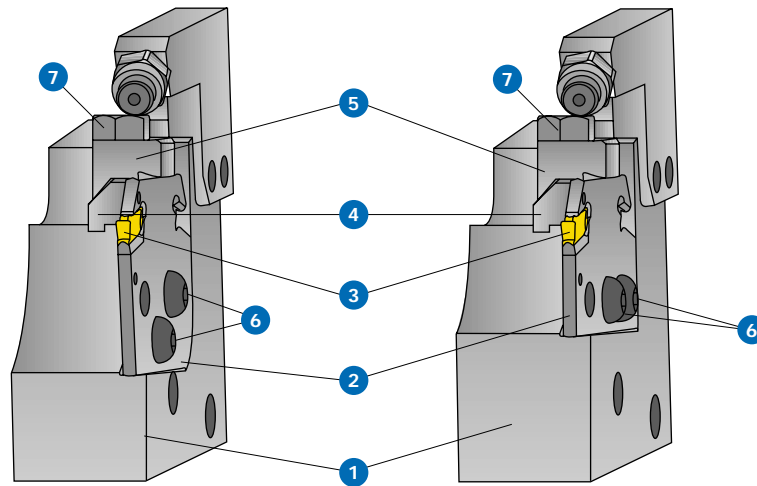

Manchester's Block 206-166 with DGAMM 48-.. Adapter

Manchester's Block 206-158 & 186 with DGAMM 38-.. Adapter

Manchester Tools					Iscar					
Block (1)	Support Blade	Clamp	W	W	Adapter (2)	Clamp (5)	Wedge (4)	Insert (3)	Dmax.	Tmax.
206-166(A)	309-111	435-136	1/8"	.079	DGAMM 48-2	BKUMM-02886	BKUS 02887	DGN/R/L 2	3"	.591
	309-105	435-103	3/16"	.118	DGAMM 48-3			DGN/R/L 3		.630
				.157	DGAMM 48-4			DGN/R/L 4		-
206-158	310-109	435-148	3/32"	.079	DGAMM 38-2		BKUS 02888	DGN/R/L 2	2.25"	.591
	310-102	435-101	1/8"	.118	DGAMM 38-3			DGN/R/L 3		.630
206-186	310-108	435-102	3.16"	.157	DGAMM 38-4			DGN/R/L 4	1"	-

Insert Extractor: EDG-33A

(6) Adapter clamping screws

(7) Clamp screw

(A) Tmax - depth of cut as a function of tube diameter:

Dtube	1"	2"	3"	4"	5"	6"	7"	8"
Tmax	-	.600	.550	.500	.450	.425	.400	.380

Comparable "Manchester" Blocks and Adapters for "Modern" Machines

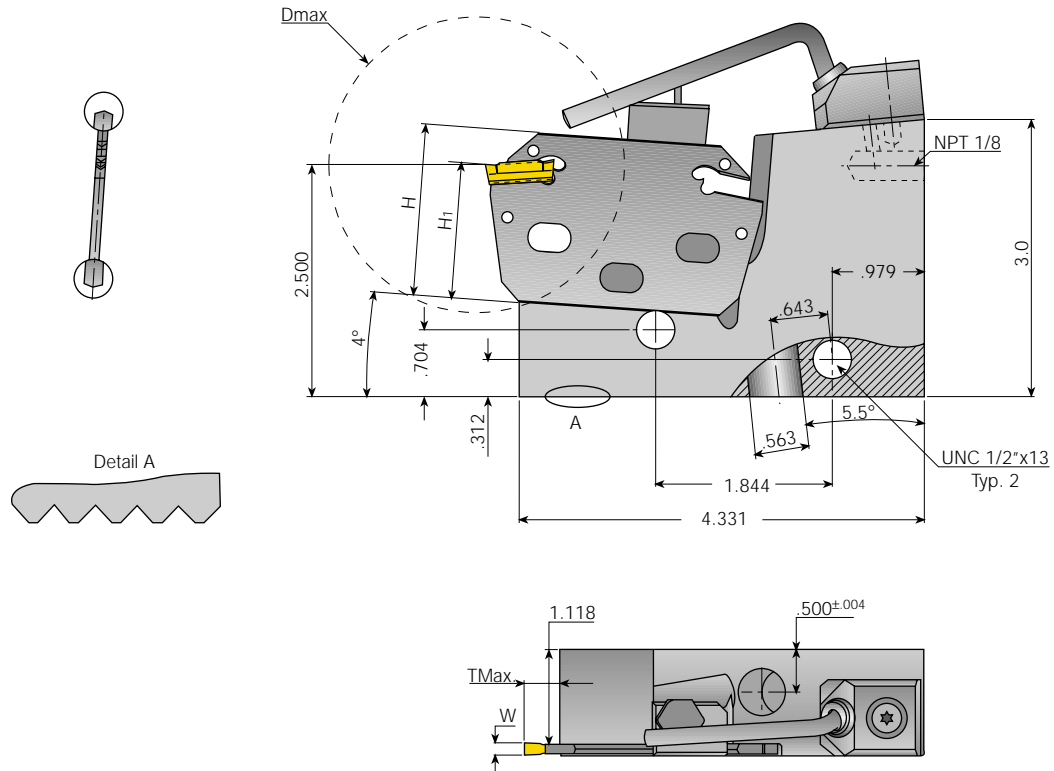

Block for Modern Cutoff Machines	Adapter	Dmax.	H ₁	H	Manchester's Block	Tmax.
GTBMM-38 / T	DGAMM 38-2/3/4	1.00"	1.092	1.496	206-186	-(A)
GTBMM-38	DGAMM 38-2/3/4	2.25"	1.092	1.496	206-158	-
GTBMM-48	DGAMM 48-2/3/4	3.00"	1.487	1.890	206-166	-

- (1) Block
- (2) Adapter
- (3) Insert
- (4) Clamp wedge: BKUMM-02886
- (5) Clamp screw: UNC-5/16x1"
- (6) Cooling system: EZA 03319

(A) Tmax - depth of cut as a function of tube diameter:

D _{tube}	1"	2"	3"	4"	5"	6"	7"	8"
Tmax	-	.600	.550	.500	.450	.425	.400	.380

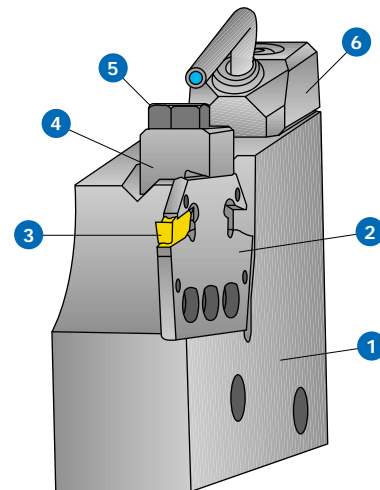

DGAMM Adapters for "Modern" Machines

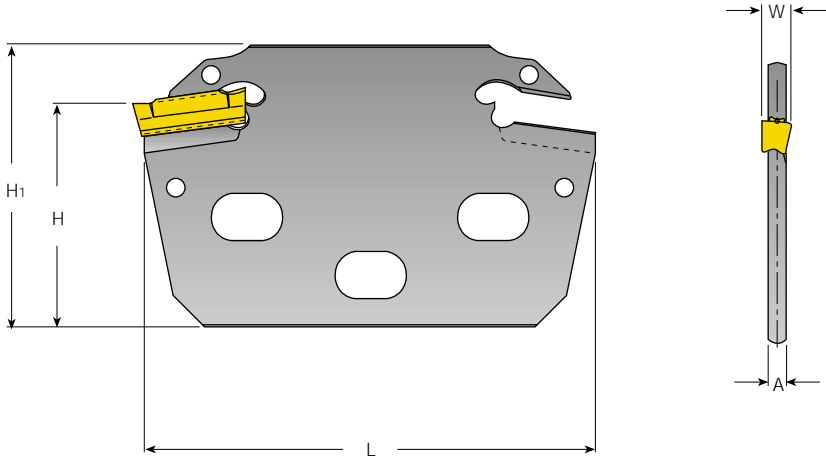

Blade	W	A	H1	H	L	Key	Inserts
DGAMM-38-2	2	1.6				EDG 33A	DG□2...
DGAMM-38-3	3	2.4	38	27.73	62.6		DG□3...
DGAMM-38-4	4	3.2					DG□4...
DGAMM-48-2	2	1.6					DG□2...
DGAMM-48-3	3	2.4	48	37.77	75.9		DG□3...
DGAMM-48-4	4	3.2					DG□4...